



**RSM/RSP/RSE/RSE-B/
RSMINI163/RSMINI/RSMINI-P
User Guide**

Description: The RacSense Series consist of Power Distribution Units and Environmental Monitors with a built in web server in a self-contained unit. Web pages, including graphs, are generated from the unit, and monitor power and environmental conditions within the cabinet. No software other than a web browser is required, and several data formats are available. Models are available with a wide range of onboard features; not all features are available on each model.

Specifications (See Unit Label for Ratings):

Networking: HTTP, HTTPS (SSL/TLS), SMTP, POP3, ICMP, DHCP, TCP/IP, NTP, FTP.

Data Formats: HTML, SNMP, CSV/Plain Text, Telnet, WAP, PDA formatted HTML, XML.

EMC Verification: Class A digital device. This device complies with part 15 of the FCC Rules. Operation is subject to the following two conditions: (1) This device may not cause harmful interference, and (2) this device must accept any interference received, including interference that may cause undesired operation.

Warning: Changes or modifications to this unit not expressly approved by the party responsible for compliance could void the user's authority to operate this equipment.

Receptacle Ratings:	NEMA 5-15R	125 Volts, 15 Amps	NEMA 5-20R	125 Volts, 20 Amps
	NEMA 6-20R	250 Volts, 20 Amps	IEC320 C13	125/250 Volts, 15 Amps

Model Options:

MODEL	Power Distribution	Built In Display	Remote Display Compatible	# Remote Sensor Ports	Temperature	Relative Humidity	Airflow	Light Level	Sound Level	I/O Ports	Volts	Amps	Power
RSM	√		√	4, expandable to 16	√	√	√	√	√	√	√	√	√
RSP	√		√	0							√	√	√
RSE		√		5, expandable to 16	√	√	√	√	√	√			
RSE-B				5, expandable to 16	√	√	√	√	√	√			
RSMINI163				16	√					√			
RSMINI/RSMINI-P				1, expandable to 16	√								

Installation:

- Using appropriate hardware, mount in rack or cabinet.
- Plug into an appropriately rated and protected branch circuit receptacle.
- Connect to network using Ethernet connection.
- Connect any External Sensors (Optional) to the unit.
- Plug in devices to be powered by PDU.
- Power on devices to be powered by PDU. Sequential power up is recommended to avoid high inrush current.

Service and Maintenance:

No service or maintenance is required. **Do not attempt to open, warranty will be void.** No user serviceable parts inside.

Setting an IP Address

The unit has a permanent IP address for initial setup and access should you forget the address you assign to it. The Configuration page allows you to assign the network properties or configure DHCP to connect to your network. Access to the unit requires the IP address to be known, use of a Static IP or reserved DHCP is recommended. The permanent address is shown on the front of the unit.

IP Address: 192.168.123.123

Net Mask: 255.255.255.0

Gateway: 192.168.123.1

First time setup:

1. Connect unit to your computer using a crossover cable.
2. On your computer, go to “Start > Settings > Control Panel > Network and Dial Up Connections”
3. Right Click on “Local Area Connection” and select “Properties”
4. Select the option to “Use the following IP address” and enter:
 - IP address: 192.168.123.1
 - Subnet mask: 255.255.255.0
 - Gateway: “Not Needed”
5. Click “OK” twice
6. You can now access the unit using your web browser at the permanent IP address, <http://192.168.123.123>

Typical Network Card Settings for PC or Laptop to connect to backup IP address. Note that a Default Gateway is not needed nor recommended.

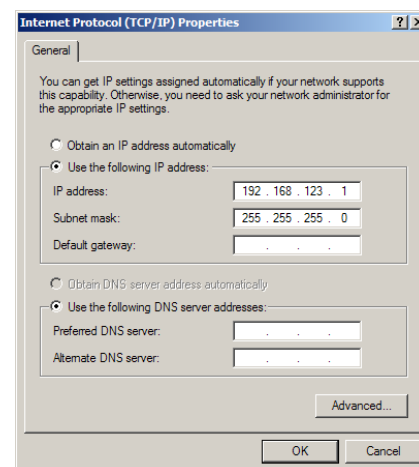

Internal Sensors (Options vary per Model)

All internal sensors are measured every 5 seconds. External sensors are measured every 10 to 30 seconds depending on the number of devices connected. Sensor data collected by the product gives useful trend analysis data. While all values are not absolute in relation to a known unit, trend analysis of the data allows users to view changes in data value over time. Analysis of the change in value of the data can lead the user to useful conclusions about what is happening in the monitored environment. Because much of the unit-less data is relative, it may not be reasonable to expect similar values from sensors mounted in non-adjacent locations.

Temperature – Measures temperature and can be displayed in °C or °F. The accuracy is $\pm 1^\circ\text{F}$ from -50°F to 185°F . Note this sensor may be heated by internal circuitry in the unit; a temperature offset is available to re-calibrate.

Relative Humidity – Measures the percent of Relative Humidity $\pm 5\%$.

Airflow – Airflow is a unit-less measurement. A reading of 0 to 99 is based on the temperature drop of a heated element in open air vs. still air. This value can be set to 20 in any airflow condition using Telnet. Note: Due to the method of measurement sharp changes in temperature can affect the accuracy of this sensor. Sensitivity will also be affected by temperature.

Light Level – Light Level provides a reading of 0-99, is a unit-less measurement.

Sound Level – Sound Level provides a reading of 0-99, is a unit-less measurement.

IO-1 – Scales 0 to 5Vdc input to 0-99, dry contacts may be used.

IO-2 – Scales 0 to 5Vdc input to 0-99, dry contacts may be used.

IO-3 – Scales 0 to 5Vdc input to 0-99, dry contacts may be used.

Volts – Measures instantaneous RMS voltage.

Volts (Peak) – Reports the highest reported voltage since the last time the data was updated, typically every 5 seconds.

Amps – Measures instantaneous RMS current.

Amps (Peak) – Reports the highest reported current since the last time the data on the screen was updated, typically every 5 seconds.

Real Power – Average of instantaneous voltage and current over the last 1.5 seconds.

Apparent Power – The product of instantaneous RMS Voltage and RMS Current. This is the value used by circuit breakers.

Power Factor – The ratio of Real Power to Apparent Power.

Temperature Offset

The internal temperature sensor is pre-calibrated at the factory and the values being reported are accurate. However, due to low airflow and normal board heating, the temperature sensor may read a few degrees higher than any external sensors that are attached. To counteract this an offset of up to -7°C or $^\circ\text{F}$ depending on the current operating mode, is configurable on the Display page.

Connecting Optional RJ Remote Sensors

Plug and Play Remote Sensors may be attached to the unit and in some cases splitters may be required to add additional sensors. Each sensor has a unique address and is automatically discovered and added to the webpage. **Note:** the display order of the sensors on the web page is determined by the internal ID of each sensor, a customizable friendly name is available for each on the Display page.

The supplied wires can be extended or shortened using Cat 3 wire and RJ12 connectors. **Note:** the sensor wire has six conductors, wiring must be straight-through: reverse polarity will temporarily disable all sensors until corrected. The sensors use a serial communication and are subject to network signaling constraints dependent on shielding, environmental noise, and length of wire. Typical installations should allow runs of up to 600 feet of sensor wire.

Optional RJ Remote Sensors

RT	Temperature
RTAF	Temperature / Airflow
RTAFH	Temperature / Airflow / Humidity
CCAT	Converts I/O Sensor to Remote Sensor

Custom lengths available upon request at 800-432-3219 or products@geistmfg.com.

I/O Ports (Options vary per Model)

The 3 I/O Ports are for connecting additional sensors such as Water and Door Sensors. The 3 ports are 0–5Vdc analog input with an internal 100k pull up resistor to 5V allowing the use of dry contacts. This is converted to a digital number of 0 to 99 on the webpage. These sensors can be renamed on the Display page.

Water sensors act as conductivity bridges. Moisture across the contacts causes the value to drop. Door switches can be wired in a serial connection, if the chain is broken the entire group is classified as open. The limiting factor on the I/O ports is the length of the wire, found to be around 400'.

Water Sensors

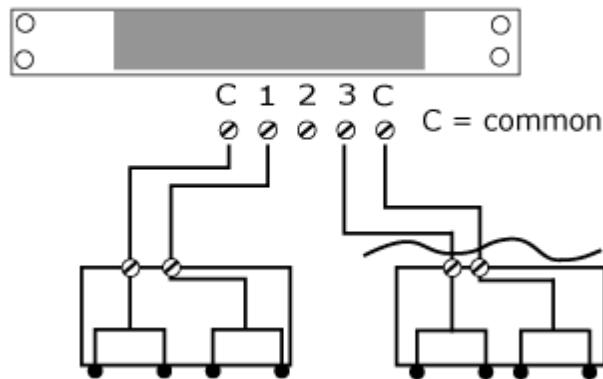

Door Switches - Extended

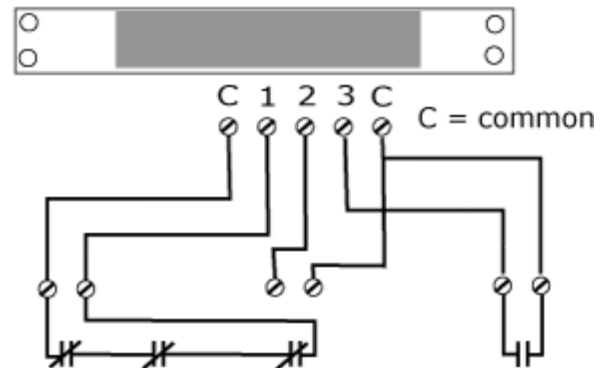

Optional I/O Sensors

RWS	Water
RDPS	Door
SA-1	Smoke Alarm
RCP-2	125V City Power Monitor
WSK-10	10' Water Sensing Cable Kit
WSK-40	40' Water Sensing Cable Kit
-48VDCM	Power Monitor
30VDCM	Power Monitor

Graphing and Displaying Data

All data collected by the unit can be graphed. The Log page allows the user to select graphed content and sampling rate, selected items will be displayed on LCD (on units where it is present, or optional Remote Display). The amount of data and sample rate determine the graph time span. This period is calculated and displayed on the Log page. When the onboard memory fills up, old data will be deleted, making room for new data. All settings are stored in case of a power loss or reboot. A sample rate of 30 seconds or longer is recommended to allow the unit to gather all sensor data before graphing. Sampling rates of 60 to 120 seconds should provide ample resolution for most situations.

Setting Alarms

For all data collected by the unit, the user can set high and low limits. When these limits are exceeded the user has the option of sending an email, SNMP trap, activate the audible alarm (on units where it is present), or any combination of the three. The SNMP traps can be sent to 4 IP addresses. Some analysis of each unit is recommended before setting alarm limits. Once each unit has been operating in the environment under normal, steady state conditions for several hours, alarm set points may be chosen. By allowing the unit to come to steady state before setting alarm set-points, the user may make more informed decisions about the normal variation in conditions and choose alarm set points that will inform when conditions are truly changing without triggering numerous false alarms. Aside from using historical graphs to make alarm set-point decisions, the user may choose to download raw log data from the logs page to see specific historical data records and use this data to help set useful alarm set-points. **Note:** Changes in settings are processed less frequently and depending on the number of attached devices may take several minutes to respond. Rapidly resetting alarm values may not provide desired results. Allow up to 2 minutes after making a setting change before modifying. Test alarms can be sent for each measured value via the Alarms page.

Optional RSD2X8 Remote Display

This small module can be mounted in an accessible spot inside or outside the rack or cabinet. A LCD display scrolls values of items selected on the Logs page. The connection to the unit is made with a 10' handset type 4-conductor cable. The buzzer can be activated for alarm states to identify problems. An alarm reset is located next to the display to silence the buzzer when the problem is located. The LED indicator stays on in alarm state even after the buzzer has been silenced.

Optional IP-Enabled Web Camera

The unit has been designed to allow up to 4 IP Network Cameras to interface with the webpage. To enable this feature the camera must be set to allow anonymous access. The unit Configuration page allows you to add the IP address of the camera and specify the model. This live image will appear on the Sensors page and will update with the webpage. Clicking on the picture itself will take you to the IP address of the camera. Each device currently supports up to 4 cameras simultaneously.

Supported Cameras: Axis 205/206, D-Link DCS-900, D-Link DCS-950/G, D-Link DCS-5300/G

Other Formats

- PDA Displays data in a small screen format for a PDA.
- WAP Wireless Application Protocol, displays text values for wireless clients such as mobile phones and some PDAs.
- XML Extensible Markup Language, displays values in XML format.
- MIB Management Information Base, downloads the MIB to be used for SNMP applications.

Accounts, Passwords and Security

The unit is accessible via a standard, unencrypted HTTP connection as well as an encrypted HTTPS (SSL) connection. The user may opt to enable access via HTTP, HTTPS, or both HTTP and HTTPS. It is not possible to disable the web interface completely.

The unit has a View-Only account, a Control Access account, and an Administrator account. When activated the Administrator account limits access to any web pages with configuration settings. When left blank no username or password is required to adjust the configuration. When activated, the View-Only account requires a username and password to view sensor data. The Control Access account allows access to the Control page, allowing configuration of attached switch-able power distribution units. The Administrator account must be password protected to activate the View-Only and Control Access accounts. The user may choose any name for the Administrator, Control Access, and View-Only accounts consisting of alphanumeric characters, spaces, and underscores, except for "root" and "admin". These account names are disabled for security reasons and cannot be re-enabled. **WARNING: Record your password. Loss of password will require the unit serial number and contact of customer service to be recovered.**

Setting Time and Date

The unit comes preconfigured with the IP addresses of two military NTP servers and set to the Central Time Zone (-500 GMT). Should a local time server be preferred, enter its IP address into the box and click the "Save Changes" button. Should the user need to revert back to the military time servers, simply clearing the time server addresses and clicking "Save Changes" will set the time

servers back to the defaults. The unit attempts to contact the timeservers while booting up. If a timeserver is unavailable, all log time stamps will present time as the number of seconds since the unit was powered up. **Note:** that the time and date are not adjusted for daylight savings time. Setting the time zone offset forward and backward an hour will cause a gap or overwriting of logs, respectively.

Telnet

When using Telnet to connect to the unit, the Administrator username and password from the Configuration page will be required. If the Administrator user is not configured, the Telnet server will be enabled, but logins will be impossible. The Telnet server can be disabled on the Configuration page. Available Telnet commands can be found by using the command "help".

The following are some commonly used Telnet commands:

Airflowset – Resets the internal airflow sensor such that the current flow is measured as '20'.

Exit – Terminates the Telnet connection.

Reboot – Reboots the controller board remotely. Power distribution is not affected.

Report – Displays a report of all connected sensors and their current values.

Time – Displays the current date and time according to the unit if the unit has contacted an NTP server.

Systeminfo – Displays general information about the unit, including: Unit type, Software version and MAC address.

SNMP

The unit is accessible via SNMP and can be configured to send out SNMP traps to a maximum of 4 IP addresses when alarm conditions are met. The community string defaults to "public," but is user-customizable on the Configuration page. The MIB is downloadable via a link at the top of the web interface. The MIB is walk-able via any SNMP browser, but will have to be imported before doing so. The SNMP service can be disabled via the Configuration page. A test SNMP trap can be sent from the Configuration page.

E-Mail

The unit is capable of sending e-mail to a maximum of 5 e-mail addresses when alarm conditions are met. E-mail settings are on the Configuration page. An SMTP server, a "From" address and a "To" address are required to send email alerts. Some e-mail servers are password protected and will require a POP server, username and password for validation. In most cases, the username does not have to match the "From" address, but does need to be a valid user on the POP server. Microsoft Exchange servers will have to be set to allow SMTP relay from the IP address of the unit. A local network administrator will have to change this setting. A test email can be sent from the Configuration page.

Daily Affirmation

Daily Affirmation allows the users to choose a frequency with which the unit will forward a full status report to their e-mail. This status report can come hourly, every 2, 4, 8, or 12 hours, or once daily (24 hours). This feature allows you to know that everything is still running, and gives you an update on all attached devices as well. Set-up of this feature is on the Configuration page under "Status Reports".

Owner Contact Information

Owner contact information can be entered on the Configuration page and will display at the bottom of the web interface.

Optional Console Integration

In addition to its own web interface, Console Software is available. Console Software allows convenient, one screen monitoring of multiple units via simple web-based interface, streamlined firmware updating and consolidation of alarm settings.

Firmware Upgrades and Additional Information

New firmware upgrades and additional information is available at <http://www.geistmfg.com/GeistUS/Docs/downloads.htm>.

Optional Accessory - CCAT

The CCAT is a Serial Bus Interface that performs an analog to digital conversion for connecting I/O sensors to the RJ Remote Sensor Ports. Each CCAT contains a unique digital address and is plug and play.

CCAT versions available: Millivolts – Used to connect RCP, Door – Used to connect RDPS, Water – Used to connect RWS

Installing a CCAT requires connecting to the remote sensor port using cable provided. Connect I/O sensor to wires, RED is (+), Black is (-). The CCAT will be auto-detected, verify I/O sensor is reading on webpage.